

Hack8 Master Link

The Hack8 master link is the cornerstone of any Hack8 chain sling assembly. It acts as the connection point between the sling legs below and the lifting machine above. A Hack8 master link is used in both one leg or two leg chain slings, as well as forming part of a Hack8 sub assembly for use with three and four leg chain slings. Manufactured from alloy steel, the Hack8 master link delivers an excellent balance between toughness and ductility.

The Hack8 master link has been independently verified and awarded the DGUV Test H-Mark for lifting components, issued under number H83.

Standards: designed and manufactured in accordance with EN1677-4 and suitable for use in chain slings certified to EN818-4.

Third-party accreditation: DGUV Test H-Mark certified under number H83.

Product sizes: available for chain sizes from 7/8mm to 20mm and with working load limits from 2.12 tonnes to 12.5 tonnes.

Temperature: operational temperature range of - 40°C to + 200°C without reduction in working load limit.

Material: alloy steel.

Testing: individually magnaflux crack detected after heat treatment and proof load tested to 2.5 times working load limit.

Safety factor: 4 : 1.

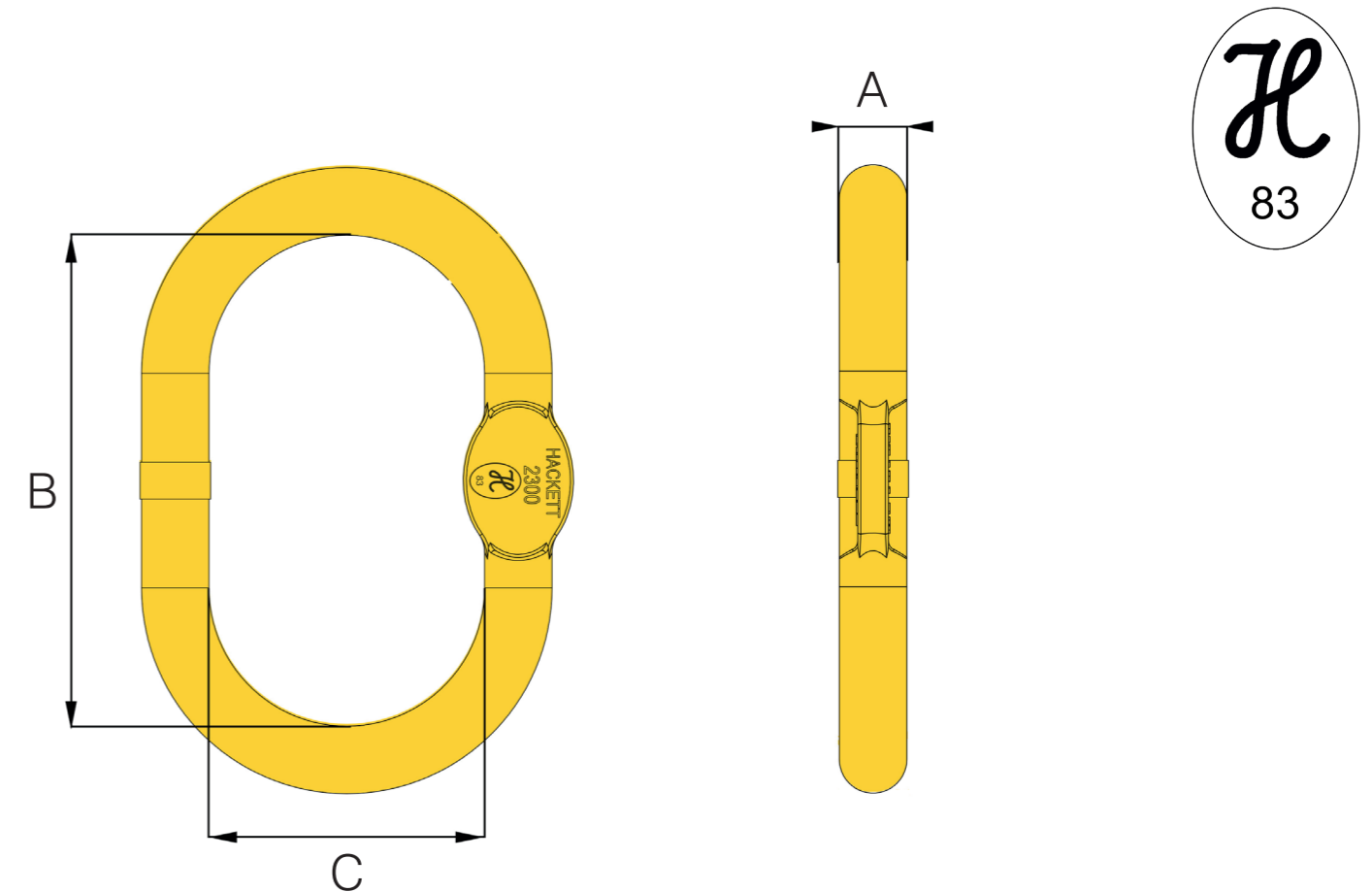

Metric Specifications

PART CODE	DESCRIPTION	CHAIN SIZE mm SINGLE	CHAIN SIZE mm DOUBLE	A mm	B mm	C mm	BOX QTY.	WLL kg	MASS kg
8-H01-0806	ML0806-8	7 & 8	6	16.0	110.0	60.0	30	2.12	0.54
8-H01-1008	ML1008-8	10	7 & 8	18.0	135.0	75.0	20	3.15	0.82
8-H01-1310	ML1310-8	13	10	22.0	160.0	90.0	10	5.30	1.50
8-H01-1613	ML1613-8	16	13	26.0	180.0	100.0	8	8.00	2.32
8-H01-2016	ML2016-8	20	16	32.0	240.0	140.0	3	12.50	5.66

Hack8 Master Link

The Hack8 master link is the cornerstone of any Hack8 chain sling assembly. It acts as the connection point between the sling legs below and the lifting machine above. A Hack8 master link is used in both one leg or two leg chain slings, as well as forming part of a Hack8 sub assembly for use with three and four leg chain slings. Manufactured from alloy steel, the Hack8 master link delivers an excellent balance between toughness and ductility.

The Hack8 master link has been independently verified and awarded the DGUV Test H-Mark for lifting components, issued under number H83.

Standards: designed and manufactured in accordance with EN1677-4 and suitable for use in chain slings certified to EN818-4.

Third-party accreditation: DGUV Test H-Mark certified under number H83.

Product sizes: available for chain sizes from 9/32 - 5/16 inch to 3/4 inch and with working load limits from 4,673 lbs to 27,557 lbs.

Temperature: operational temperature range of -40°F to +392°F (-40°C to + 200°C) without reduction in working load limit.

Material: alloy steel.

Testing: individually magnaflux crack detected after heat treatment and proof load tested to 2.5 times working load limit.

Safety factor: 4 : 1.

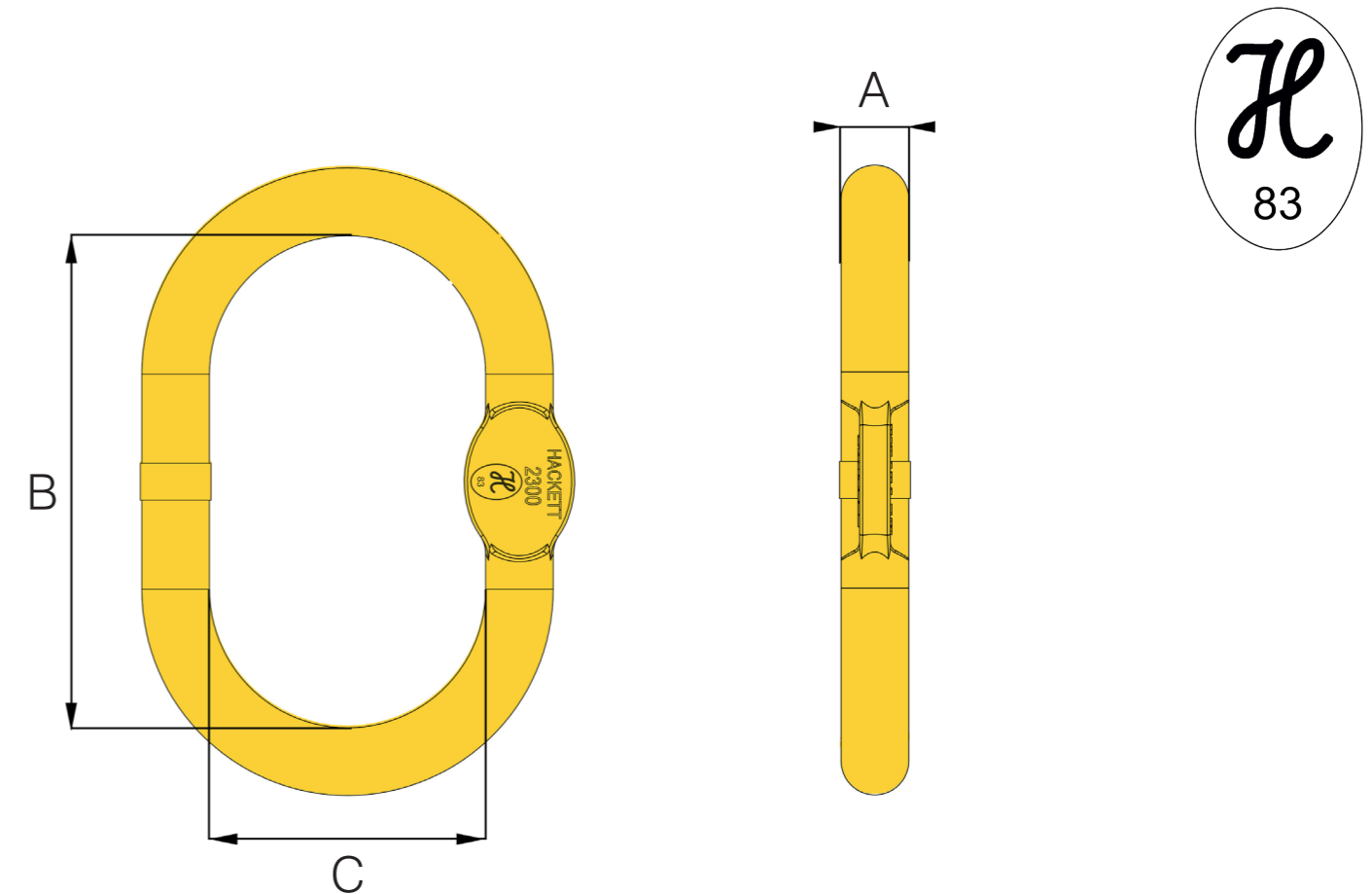

Imperial Specifications

PART CODE	DESCRIPTION	CHAIN SIZE inch SINGLE	CHAIN SIZE inch DOUBLE	A inch	B inch	C inch	BOX QTY.	WLL lbs	MASS lbs
8-H01-0806	ML0806-8	9/32 - 5/16	1/4	0.63	4.33	2.36	30	4673	1.19
8-H01-1008	ML1008-8	3/8	1/4 - 5/16	0.71	5.31	2.95	20	7100	1.81
8-H01-1310	ML1310-8	1/2	3/8	0.87	6.30	3.54	10	12000	3.31
8-H01-1613	ML1613-8	5/8	1/2	1.02	7.09	3.94	8	18100	5.11
8-H01-2016	ML2016-8	3/4	5/8	1.26	9.45	5.51	3	27557	12.48